

Installation Manual

Ver 1.00

EC Series Drives

Firmware ver: _____

Kolorrol Energy Pvt Ltd

Survey No. 423, Mahagujarat Industrial Estate, Opp. Sarvoday Hotel,

Near Pharma Lab, Moraiya, Changodar, Ahmedabad 382 213.

Phone: +91 92280 19632, +91 92280 29632

E-mail: info@kolorrol.com Web: www.kolorrol.com

Feedback: We would appreciate your feedback on our products and manual.
Send your feedback on www.kolorrol.com/feedback or mail us on info@kolorrol.com

The manufacturer accepts no liability for any consequences resulting from inappropriate,
negligent or incorrect installation or adjustment of the
optional operating parameters of the equipment or from mismatching the variable speed drive with the motor.

Table of Contents

1. Quick Start and Technical Data

1.01	Model Description	01
1.02	Control terminal layout	01
1.03	Power Terminals	02
1.04	Mounting Dimensions	02
1.05	Drive Ratings	03
1.06	Cable and Fuse selection	04
1.07	Dimensions and Weight	05
1.08	Input Line Choke	05
1.09	Brake Resistor Selection	06

2. Mechanical Installation

2.01	Planning the installation	07
2.02	Opening the drive package	08
2.03	Installing the drive	08
2.04	Removing top cover	09
2.05	Cabinet temperature rise considerations	09
2.06	Calculating Air flow requirement	09
2.07	Gaskets for enclosures	09

3. Electrical installation

3.01	Motor selection	10
3.02	Power connections	11
3.03	Control terminal connections	11
3.04	Earthing	12
3.05	AC supply	12
3.06	Input line reactors	12
3.07	Common DC bus	13
3.08	Derating	13
3.09	Braking	14

4. Safety

4.1	Warning, Caution and Notes	15
4.2	Electrical safety – general warning	15
4.3	System design and Safety	15
4.4	Access	15

1 Quick Start

1.01 Model description:

EC- xx - 4

- Voltage rating, 4: 400V series, 2: 200V series
- HP rating
- Drive series

Kolorrol Energy Pvt Ltd.
 Model: EC104
 Sr no: _____
 Input 3ph
 Vn:380-480VAC,16A,48-63Hz
 Output 3ph
 0-Vn,16A,0-500Hz,7.5KW/10hp

1.02 Control Terminal Layout

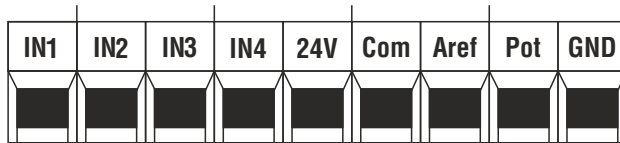

Max Torque : 0.4 Nm

Actuation voltage for digital inputs: 24V
 Minimum actuation voltage: 12V(not recommended)
 Max total output current: 200mA

Digital Inputs:	IN1,IN2,IN3,IN4	24V
Digital Outputs:		24V
Analog Inputs 12b: 0-10V	Pot - Gnd, Rin:200k	

1.03 Power Terminals

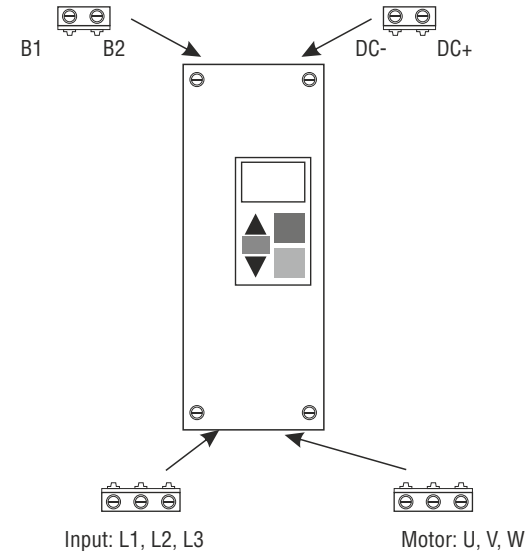

1.04 Mounting Details

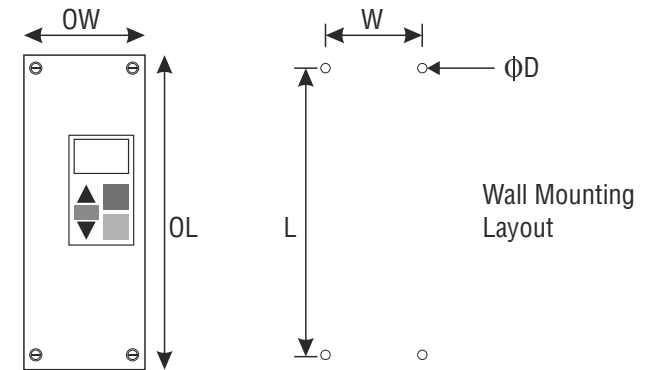

Size	L(length) mm	W(width) mm	D(depth) mm	OL(over all length)mm	OW(over all width)mm	Dmm
1	tbd	tbd	tbd	tbd	tbd	tbd
2	286	94	200	315	125	6.5
3	tbd	tbd	tbd	tbd	tbd	tbd
4	tbd	tbd	tbd	tbd	tbd	tbd
5	tbd	tbd	tbd	tbd	tbd	tbd
6	tbd	tbd	tbd	tbd	tbd	tbd

*tbd : to be disclosed

1.05 Drive Ratings

All specifications below are for a switching frequency of 3Khz and 40°C ambient temperature.

Operating temperature: -10°C to 55°C.

Model	Normal duty			Heavy Duty		
	Kw	HP	Max output current	Kw	HP	Max output current
EC-01-4	0.75	1	2.1	0.75	1	2.1
EC-02-4	1.5	2	4.2	1.5	2	4.2
EC-03-4	2.2	3	5	1.5	2	4.2
EC-05-4	3	5	6.9	1.5	2	4.2
EC-05A-4	4	5	8.8	3	5	6.9
EC-07-4	5.5	7.5	11	4	5	7.5
EC-10-4	7.5	10	16	7.5	10	11
EC-10A-4	7.5	10	19	7.5	10	11
EC-15-4	11	15	22	7.5	10	16
EC-20-4	15	20	29	15	20	25
EC-25-4	18.5	25	35	15	20	25
EC-30-4	22	30	43	18.5	25	35
EC-40-4	30	40	55	22	30	46
EC-50-4	37	50	68	30	50	60
EC-60-4	45	60	83	37	60	75
EC-75-4	55	75	104	tbd	tbd	tbd
EC-100-4	75	100	138	tbd	tbd	tbd
EC-125-4	90	125	168	tbd	tbd	tbd
EC-150-4	110	150	205	tbd	tbd	tbd
EC-200-4	132	200	236	tbd	tbd	tbd

Light duty rating: 110% overload is allowed for 1min.

Heavy duty rating: 150% overload is allowed for 1min.

1.06 Cable and Fuse selection chart

Drive model	Rated input current(A)	IEC fuse gG rated current(A) 500V	UL fuse class T 600V	Cable size	
				mm2 EN60204	AWG UL508C
EC-01-4	3.2	6	6	0.75	16
EC-02-4	5.6	10	10	0.75	16
EC-03-4	6.8	10	10	1	16
EC-05-4	10	16	15	1.5	14
EC-07-4	12.6	20	20	2.5	14
EC-10-4	15.7	25	25	4	12
EC-14-4	20.2	25	25	4	10
EC-15-4	20.2	32	35	4	10
EC-20-4	26.6	40	35	6	8
EC-25-4	34.2	50	45	10	6
EC-30-4	40.2	50	50	16	6
EC-40-4	51.3	63	70	25	4
		IEC fuse gR			
EC-50-4	61.2	80	80	25	3
EC-60-4	76.3	100	100	35	2
EC-75-4	94.1	125	125	70	1
EC-100-4	126	200	200	95	2/0
EC-125-4	152	250	250	120	4/0
EC-150-4	224	315	350	2x70	2x2/0
EC-200-4	247	315	350	2x120	2x4/0

Note:

PVC insulated cables should be used.

Cables selection is as per IEC60364-5-52 , cable installation method B2(multi core cable in conduit), ambient temperature 40°C with correction factor of 0.87.

B1 – separate cables in conduit

C- multicore cable in free air.

Cable sizes may be reduced depending upon ambient temperature and installation conditions.

Refer to local wiring regulations for correct sizes of cables.

A fuse or other protection should be used between all live connections to the ac supply.

A MCB or MCCB of appropriate ratings can also used in place of the fuse.

Maximum Cable Length at 3Khz switching frequency:

For EC01xx to EC40xx = 150m(490ft)

For EC50xx to EC200xx = 250m(820ft)

1.07 Dimensions and weight

Drive size	Drive model nos	H (mm)	W (mm)	D (mm)	Weight (kg)
1	EC-01-4 EC-02-4 EC-03-4 EC-05-4	tbd	tbd	tbd	tbd
2	EC-07-4 EC-10-4 EC-10A-4	315	125	200	6kg
3	EC-15-4 EC-20-4 EC-25-4	tbd	tbd	tbd	tbd
4	EC-30-4 EC-40-4	tbd	tbd	tbd	tbd
5	EC-50-4 EC-60-4 EC-75-4	tbd	tbd	tbd	tbd
6	EC-100-4 EC-125-4	tbd	tbd	tbd	tbd
7	EC-150-4 EC-200-4	tbd	tbd	tbd	tbd

1.08 Input line Choke Selection

Model number	Value	Rated current(A)
EC-01-4	7mH	2.5
EC-02-4	4mH	4.5
EC-03-4	3mH	5.5
EC-05-4	1.7mH	10
EC-07-4	1.3mH	12
EC-10-4	1mH	17
EC-10A-4	0.7mH	23
EC-15-4	0.7mH	23

Drives of rating higher than EC-15-4 have built in dc chokes or line chokes.
For further reference and choke calculation ref to **section 3.06**

1.09 Braking resistor values

Model no	Min Brake resistor in ohms (symbol)	Instantaneous Braking power (kw)	Average power for 60s (kw)	Recommended resistor value for 10% duty cycle
EC-01-4	tbd	tbd	tbd	tbd
EC-02-4	100E	6.5	3	100E,120W
EC-03-4		6.5	3	100E,120W
EC-05-4	51E	12.5	4.4	51E,250W
EC-07-4		12.5	7	51E,250W
EC-10-4	33E	19.3	9.1	33E,350W
EC-10A-4		19.3	9.1	33E,350W
EC-15-4	25E	25.6	13.1	25E,500W
EC-20-4	18E	35.5	19.3	18E,650W
EC-25-4			22.5	18E,650W
EC-30-4	10E	64	27.8	10E,1200W
EC-40-4		64	33	10E,1200W

For models above EC40-xx, Brake chopper is optional.

2. Mechanical Installation

This chapter describes mechanical installation of a drive inside a cabinet or for standalone application.

2.01 Planning the installation

Drives are suitable for indoor use in a Pollution degree 2 environment. This means that non conductive pollution environment is suitable for normal operation.

Important considerations:

- In areas with heavy dust, suspended particles it is recommended to select a gasketed cabinet with dust filters.
- Cabinet should be sufficiently rigid to support the drive.
- Sufficient clearance should be provided above and below the drive for proper air circulation and wiring access.
- If the assembled cabinet is to be transported appropriate anti vibration measures should be used to prevent excessive vibration and shock during transportation. This can be done by placing anti vibration pads at the cabinet bottom surface.

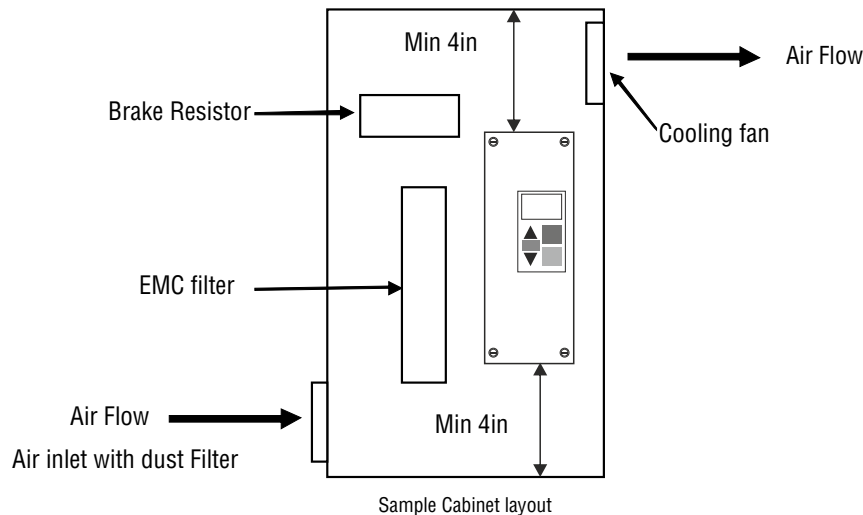

- Cabinets should be placed in areas where there are no splashing or dripping liquids.
- Cabinets should have provision for forced cooling to remove hot air from the top and take in cold air from the bottom. Gratings should be provided at the air inlet and outlet to guide the air flow.

2.02 Opening the drive package



Contents of the package:

1. Drive unit
2. Optional IP56 grommet kit.
3. User manual
4. CD with detailed user manual
5. Optional units as ordered.
For eg: remote on/off unit, extra cables etc.

2.03 Installing the drive

The drive can be installed either in a cabinet or can be wall mounted.

Mounting dimensions



The drive should never be placed horizontally or mounted on table top as this could cause over heating.



The drive should be installed indoors.

Note: All drives are intended for use without further enclosure and comply with table- 11, clause 4.3.7.3 of IEC61800-5-1:2007.

2.04 Removing the top cover for wiring

The top cover of the drive should be removed as shown for input, output and control wiring.



 Before removing the top cover drive should be isolated from the mains supply. After disconnecting mains supply drive capacitors hold charge for about 10mins. Drive should be accessed only after this period.

2.05 Cabinet temperature rise considerations

Approximately 2% losses can be considered for power dissipation inside an enclosure. These values are for Tamb = 40°C and switching frequency = 3Khz

$$\text{Surface area of the enclosure } A_{\text{encl}} = \frac{\text{Power dissipation inside enclosure}}{K \times (T_{\text{internal}} - T_{\text{amb}})}$$

T_{internal} = Maximum permissible temperature inside the cabinet
(suggested 50°C or 10°C greater than Tamb)

K = Heat transmission coefficient of enclosure material in $W/m^2/^\circ C$.
= 5.5 $W/m^2/^\circ C$ for painted sheet steel

T_{amb} = Ambient temperature

A_{encl} = surface area of enclosure

Eg: Consider a case of 2 nos 10hp drives in an enclosure.

Now total power dissipation = 2% x 7500W = 150W. Add dissipation of any other components inside the enclosure.

Taking $T_{\text{amb}} = 40^\circ C$ and $T_{\text{internal}} = 50^\circ C$

Now, $A_{\text{encl}} = 150/5.5 \times (50 - 40) = 2.72m^2$

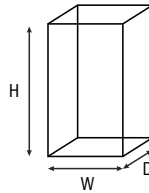

$$A_{\text{encl}} = W(H+D) + 2HD$$

2.06 Calculating Air flow requirement in an enclosure

$$\text{Air flow CFM} = 3.16 \times P / (T_{\text{internal}} - T_{\text{amb}})$$

Consider the same example of 2 x 10hp drives in an enclosure.

Total power dissipation = 150W



Required air flow CFM = $3.16 \times 150 / (50 - 40) = 47.4$

2.07 Gaskets for enclosures

Adhesive tape gaskets can be used for drive enclosures to prevent moisture and dust ingress. Neoprene closed cell adhesive tape can be used for this purpose.

3 Electrical installation

This chapter describes procedures for electrical installation of the drive unit.

-  Risk of lethal electric shock at input(L1,L2,L3), output(U,V,W), dc brake(B1,B2), dc bus(+,-) terminals
-  After disconnecting mains supply drive capacitors hold charge for about 10mins. Drive terminals should be accessed only after this period.
-  Drive should be disconnected from the mains supply before accessing terminals for wiring.

3.01 Motor selection

If multiple motors are connected to a single drive they will all run with the same speed reference. Also, the sum of the kw rating of each motor should be less than the drive kw rating. Depending upon the number of motors used the reduction in total rating could be more.

Motor selection table for reference purposes. 1500rpm, 4 pole, TEFC, 50Hz, 415V
Note: Exact ratings of the installed motor should be referred to.

HP	KW	Current (A)
1	0.75	1.75
2	1.5	3.25
3	2.2	4.55
5	3.7	7.3
7.5	5.5	10.4
10	7.5	14.5
15	11	20.5
20	15	27.6
25	18.5	33.2
30	22	39
40	30	51.5
50	37	64
60	45	76.5
75	55	94
100	75	124
120	90	149
150	110	180
200	150	248
240	180	300

Motor selection table

3.02 Power connections

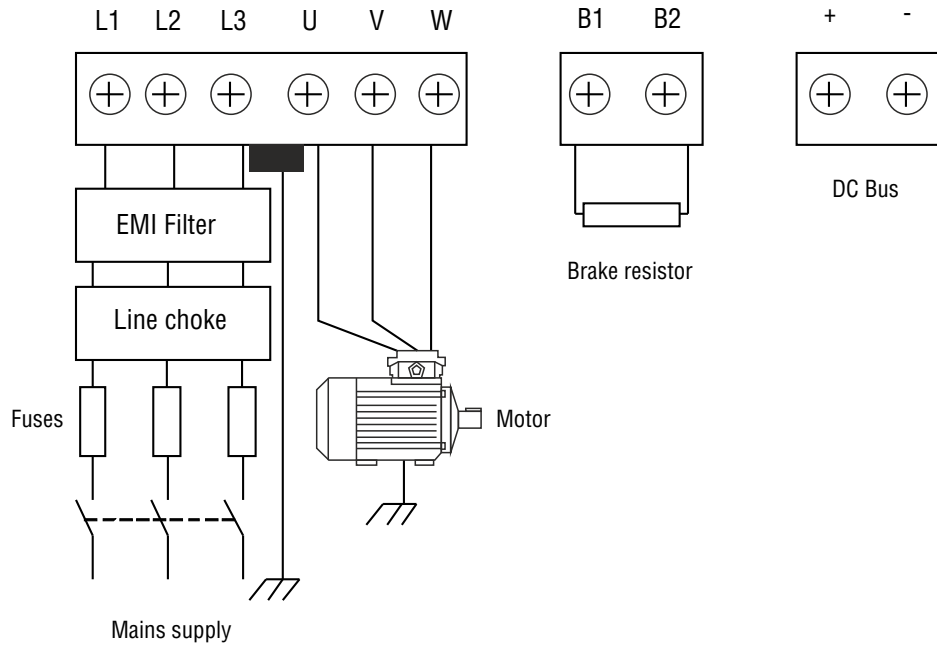

3.03 Control terminal connections

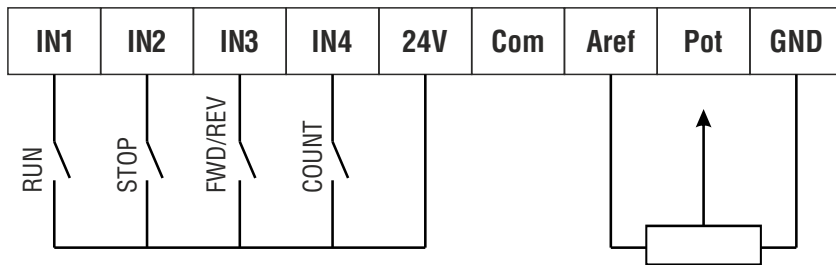

Control Cables: 26-14AWG, Torque – 0.4Nm
Total output current should not exceed 0.2A

3.04 Earthing

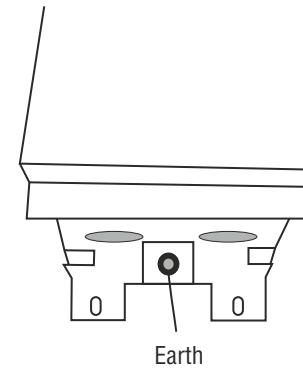

As per IEC61800-5-1 following earthing systems are possible:

1. TN
2. TT
3. IT

Operation with IT(ungrounded)supplies

⚠ Using internal or external EMI filters with ungrounded supplies, could overstress filter or drive could fail to trip in the event of an earth fault. As a default factory setting, drives are shipped with internal RF capacitor earth link removed.

⚠ Touch current through protective conductor exceeds 10mA DC or 3.5mA AC if internal RF capacitors are connected to protective earth.

3.05 AC supply voltage

EC-xx-4 series 380V to 480V ± 10%,
50hz or 60Hz ±2% (as per IEC61800-3, 2nd environment),
3 phase

Maximum voltage unbalance producing a negative sequence component of 3% is allowable. (as per IEC61800-3, 2nd environment)

All drive series are suitable for Overvoltage category III or lower(as defined in IEC61800-5-1).

3.06 Input Line reactors

Input line reactors protect the drive from damage in case of power line disturbances and imbalances. Input line reactors of approximately 2% impedance are preferable for input protection.

Supply line disturbances are caused by:

1. Large motors operating on DOL starters
2. Power factor correction equipment

These disturbances can cause excessive input current to flow in the drive and also cause nuisance tripping. Each drive should have its own input line reactor.

Input line reactor ratings:

Rated continuous current of the reactor should not be less than the input current rating of the drive.

For a 2% impedance reactor, the inductance value can be calculated as follows:

$$L = \frac{2}{100} \times \frac{V}{\sqrt{3}} \times \frac{1}{2\pi f I}$$

Where V = Input voltage across phases

f = Input line frequency

I = Rated drive input current

Ref to table 1.09 for input line choke selection

Models EC-20-4 (20hp)onwards have internal DC chokes.

Models EC-125-4(125hp) onwards have internal AC chokes

3.07 Common DC Bus

DC bus of multiple drives can be paralleled if operating from a single dc supply. This can be done in case of a common regenerative dc supply or to avoid dc bus over voltage if one of the drives is regenerating and the other is in the Motoring mode.



Soft start action is required to power up multiple drives on a common dc bus. This can be accomplished by a three phase bridge rectifier arrangement or a line controlled converter.

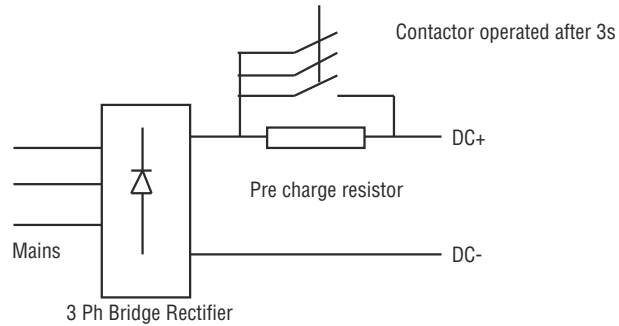

Pre charge resistor should be selected properly. Peak charging current depends on the number of drives in parallel and their KW ratings. Consult factory for pre charge resistor selection.

3.08 Derating

Drive output ratings have to be derated with temperature, switching frequency and altitude. All continuous ratings are at 40°C ambient, 3khz switching frequency and 1000m altitude. Ambient temperature derating of 1% is applied for every 1°C rise in ambient temperature above 40°C. Eg: At 55°C ambient, drive output rating is reduced to 85% of rated value.

Altitude derating

Altitude range : 0 to 3000m above sea level

Above 1000m (above sea level) reduce maximum output current by 1% per 100m.

For example at 2000m(above sea level) the maximum drive output current reduces by 10%.

3.09 Braking

Dynamic braking is required to stop or decelerate the drive in case of loads with high inertia. Without dynamic brake , these loads could cause over voltage tripping. Use of dynamic brake can be avoided if more than one drives are connected to a common dc bus. In this way regenerated energy is fed back to the drives in motoring mode. See **section 1.10** for recommended braking resistor values.



Braking resistor values below min permissible values of table 1.10 should never be used. This could cause permanent damage to the drive.

Braking resistor values in table 1.10 are for a braking duty cycle of 1/100. For higher braking duty cycles , braking resistor wattage has to be increased.

Metal clad braking resistors in aluminum housing can be used as braking resistors.

Recommended braking resistors: Enapros, www.resistorsonline.com



Braking resistors might be required to be mounted on a fan cooled heatsink if power dissipation is higher.

Safety

4.1 Warning, Caution and Notes



A warning contains information necessary to avoid a safety hazard.

4.2 Electrical safety – general warning

The voltages used in the drive can cause severe electrical shock and/or burns, and could be lethal. Extreme care is necessary at all times when working with or adjacent to the drive.

Specific warnings are given at the relevant places in this User Guide

4.3 System design and Safety

The drive is intended to be used as a component in a system or equipment. Professional knowledge of electrical systems and the drive is essential for proper installation. If installed incorrectly there may be a safety hazard.

High voltages and currents, stored electrical charge are present in the drive.

Electrical installation and system design should be done carefully to avoid safety hazards during operation or malfunction.

Stop command on the drive does not isolate dangerous voltages from the output of the drive.

Drive parameters must be set considering all the safety aspects of the application.

For eg: In torque mode, there is a risk of high speeds in case of very low load torque as compared to the reference torque. Over speed threshold should be properly setup to ensure safety.

Important system design considerations:

1. Ensure proper cable sizes(or ratings)
2. Ensure proper tightening of all electrical connections
3. Drive rating should be compatible with the motor being used.
4. Drive rated current should be properly set.

4.4 Access

Drive access must be restricted to authorized personnel only.